

Copyright 2000 - Andrew Sheldon

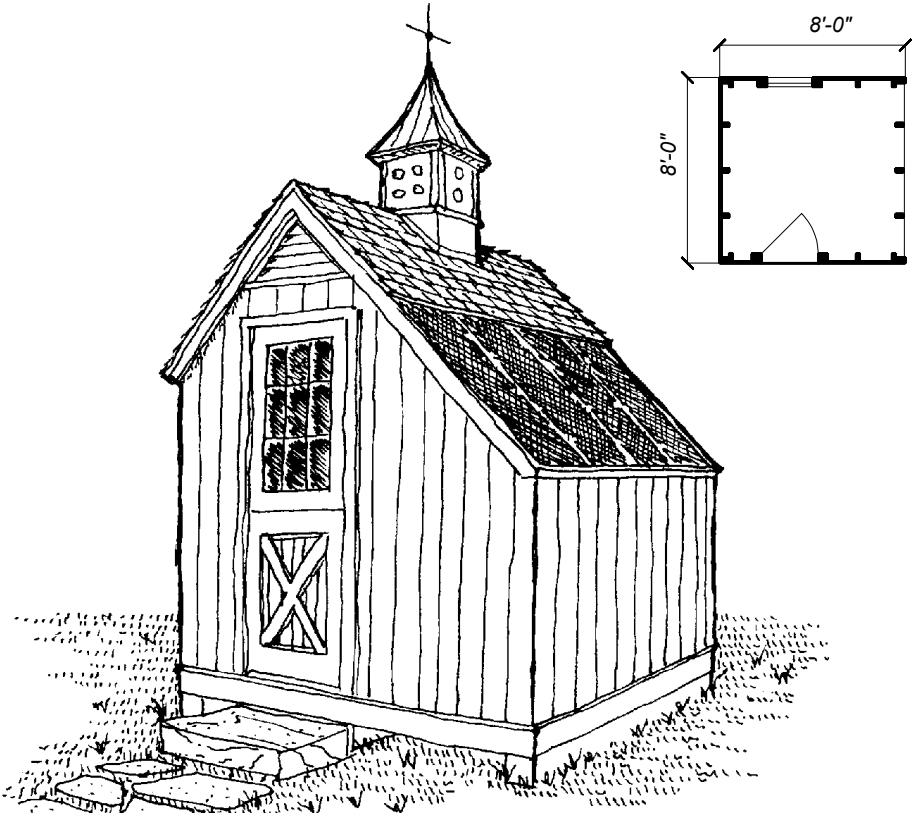

Plan #GH101 - 8' x 8' Greenhouse or Shed - \$19

This little greenhouse is constructed on pressure treated skids making it mobile and in many communities it will be considered a temporary structure. It is constructed of 2x4's obtainable at any lumber yard. The roof glazing is a single sheet of acrylic, or if you prefer, the roof glass can be eliminated and the building used as a shed. A 2ft module makes the design easily expandable if the 8ft length does not fit your needs. A material list is included in the drawing.

SHELDON DESIGNS, INC.

Welcome !

*My name is Andy Sheldon. I am an architect and have been designing small houses and farm buildings for over 25 years. My mission at **SHELDON DESIGNS** is to provide you with beautiful, economical, easy-to-build designs with complete blueprints at reasonable prices. This catalog contains some of my favorite small buildings. Each design that I offer specifies standard building materials readily available at any lumber yard. (I also have a reasonable source for logs for my log designs)*

When we receive your order, we will make every effort to process and ship within forty-eight hours. You should receive your detailed blueprints in approximately seven to ten days and your credit card will not be charged nor your check deposited until your plans are shipped. Your satisfaction is our highest priority. If you are dissatisfied in any way, you may return the order within 30 days for a full refund or exchange the plans for another design. If you have questions or need assistance, give us a call and we will try to help.

Any design can be modified to your particular needs, (I charge \$1.50/sf for this service). If you don't find exactly what you want, just drop me a note with your requirements, and maybe I can help.

Best regards,

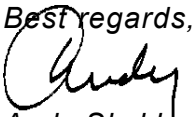

Andy Sheldon

Customer Service: (609)683 - 4388 - 9:00am - 2:00pm Eastern Time

*This plan book and the designs herein have been copyrighted by Andrew Sheldon - 1999
All Rights Reserved*

8' Wide Pole-Building Garden Sheds

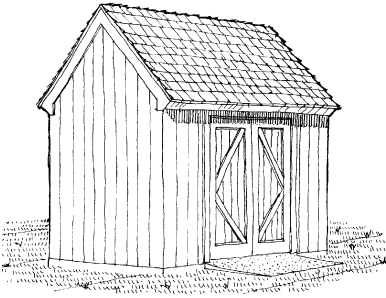

#S801P - Gable Style \$34

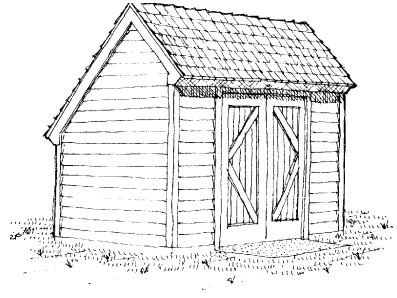

#S802P - Saltbox Style \$34

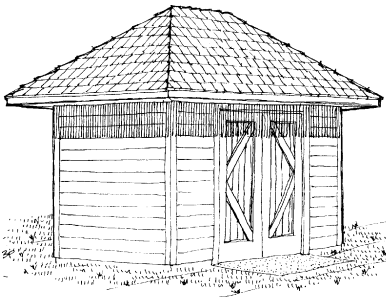

#S803P - Hip-Hoof Style \$34

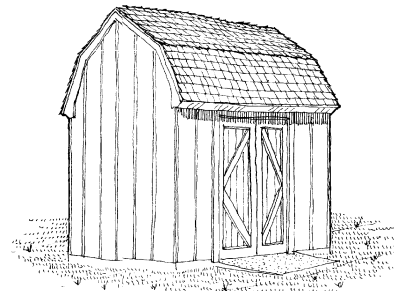

#S804P - Gambrel Style \$34

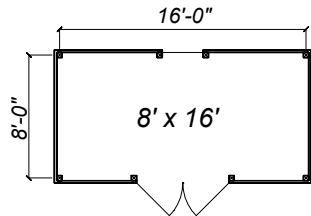
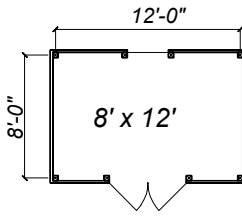
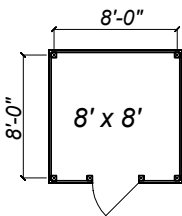

Copyright 1994 - Andrew Sheldon

These small pole-buildings come in three widths of 8ft, 12ft, and 16ft, which are all included in the blueprints. The smaller 8' x 8' size is perfect for tool storage in the garden. The 12ft and the 16ft width are useful for larger items and with the double doors, they allow easy access for lawn equipment. The saltbox style has been used as a "check-out" building for a nursery and Christmas tree farm.

12' Wide Pole-Building Garden Sheds

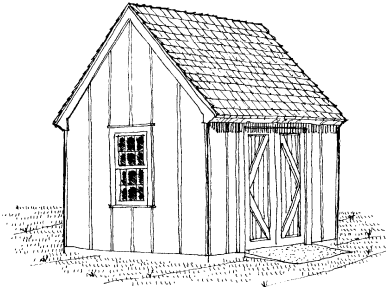

#S1201P - Gable Style \$39

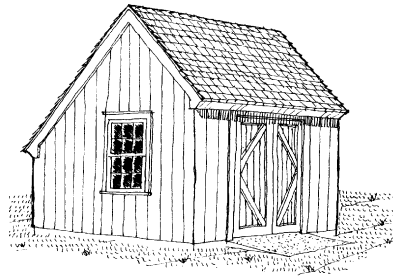

#S1202P - Saltbox Style \$39

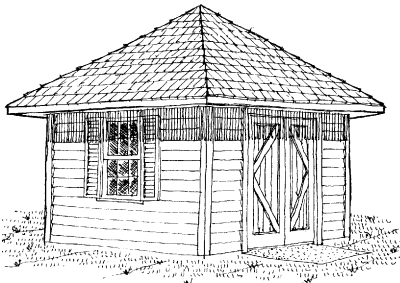

#S1203P - Hip-Roof Style \$39

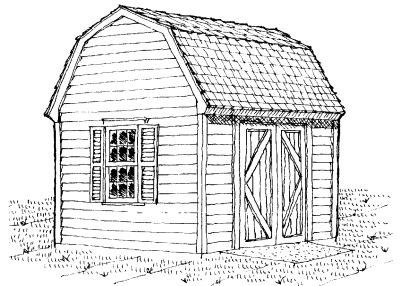

#S1204P - Gambrel Style \$39

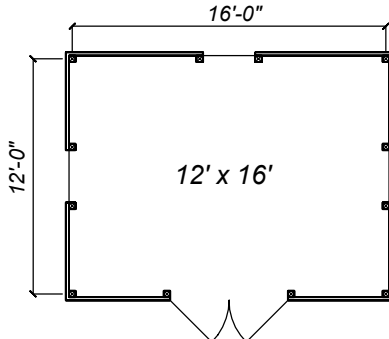
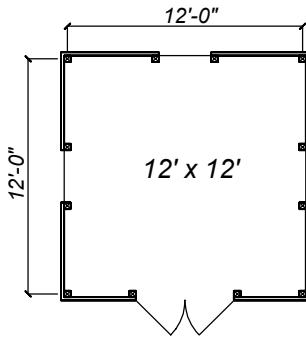

Copyright 1994 - Andrew Sheldon

These 12ft pole buildings are appropriate for larger types of equipment and tools and come in 12ft and 16ft widths, both included in the blueprints, The 16ft width can be used as a small barn. A child's playhouse is one of the many uses that the saltbox style pole building has taken and the hip-roof style was once used for a ticket booth and box office for an outdoor theater. The gambrel version is perfect for those who need more room overhead.

16' Wide Pole-Building Garden Sheds

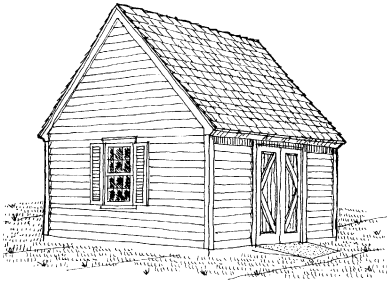

#S1601P - Gable Style \$44

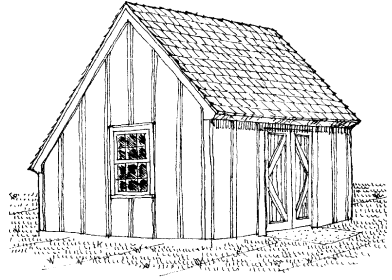

#S1602P - Saltbox Style \$44

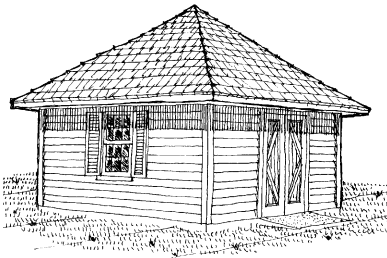

#S1603P - Hip-Roof style \$44

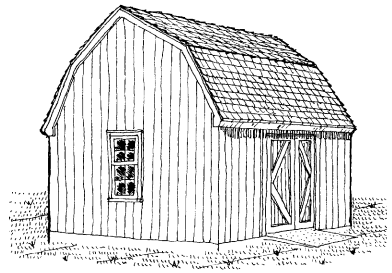

#S1604P - Gambrel Style \$44

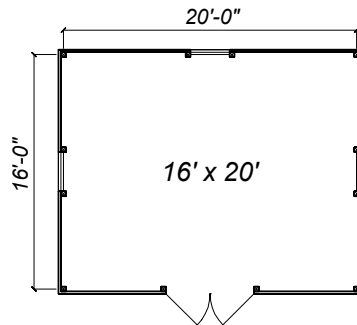
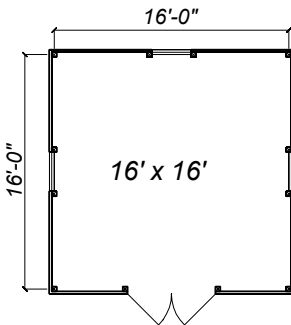

Copyright 1994 - Andrew Sheldon

The 16ft series of pole sheds approaches being both a shed a small barn or workshop. The gable style, shown here with horizontal siding, is a basic design suitable for many uses such as a craft shop or small cabin. The hip-roof style is appropriate when a larger roof overhang is desired. The gambrel-roof style provides more storage overhead and is very suitable as a workshop or a single-stall animal barn. Both of the above widths are included in the blueprints.

What Others Say About Our Plans !

"... I wanted to tell you what a pleasure it is working with your blueprint drawings. They have a very nice crispness and clarity you handle notes and specifications in a manner that doesn't clutter the drawing."
(Doug Raynor, Raynor Woodworking)

" It is a pleasure to have blueprints which are clear and informative."
(Glen Doyle, Doyle Builders)

" ... the builder complemented your working drawings. They were explicit and easy to read."
(Peter Ritchie, Landscape Architect)

"A colleague referred me, ... your barn plans are superb."
(J.S.B., MD)

"We have found your drawings to consistently be of the highest quality in terms of clarity, content, detail, creativity, comprehensiveness, and value. Your attention to detail assures that the client knows what he or she is receiving, the builder knows what he or she is building, and I know what I'm supplying. "
(Keith B. Coleman, Hamilton Supply Company)

Hints for Your Success

The pictured designs have been developed and issued without knowledge or reference to a specific geographic or municipal location and therefore we cannot guarantee local code compliance or individual interpretation of the code. It is the owner's responsibility for full compliance with all governing code requirements for the geographic and municipal area in which this design is to be built, The drawings and specifications are intended to be a general guide and outline for an experienced builder of the intent of what to construct. It is expected that those performing the work understand and know the details of their craft and have the ability and expertise to construct the designs described herein and work out certain construction details on site. If you have never attempted to construct a building of the scope of these designs, I recommend that you get professional help.

Construction Costs

From conversations with customers across the country, we have heard a very wide range of square foot costs. This is probably due to many of you building our designs yourself, whereas others are using a general contractor. The range we have been told is from \$25/sf to \$250/sf. The lower figures are coming from rural warmer areas where our cabins are self built and used as “weekend retreats”, un-insulated, with very rustic and inexpensive finishes. The larger figure represents contractor built retail costs in more expensive metropolitan areas. These buildings typically are used as guest cottages with a high level of finishes. As you can imagine a little guest house on a Beverly Hills estate will cost much more than a rustic hunting retreat in a rural wilderness.

Builders also tell us that a project is about ½ materials and ½ labor, so if you are performing your own labor that should give you a start. The building shell (less finished, plumbing, electrical, and heating) also seems to be ½ the total cost. We recommend that you call several builders or appraisers in you area and ask for a square foot range for the building type you are interested in. After several calls, the same numbers will keep popping up. Local knowledge is always the best.

Materials Lists

Material lists are available for some of our plans. The more recent designs have material lists available and as we get time, we will develop material lists for the older plans. Each design in the catalog will say if a material list is available. If there is no mention of a material list for a particular design, one is not available.

Our plans are very specific with respect to the shell materials, and most building supply houses can do a take-off and supply you with material costs. The finish materials such as lighting, floor finish, plumbing fixtures, tile, etc. is left to the owner to select the specific brands, colors, etc.

Modifying our Designs

Our plans have been designed to take into consideration your need to modify and change our designs to make the building fit your exact requirements. Changes such as are listed below can be easily made by you or your builder.

Add, delete or relocate a window or door.

Change swinging doors to sliding barn-type doors.

Change roofing materials. (shingles, metal, etc.).

Change siding material (horizontal, barn-board, board-&-batten).

Change roof pitch (although this will affect the design concept).

Finish off a loft for a studio or office.

Add or eliminate animal stalls.

Change the use of the building.

Any of the above can change the character of the design to meet your needs. A barn-style becomes colonial with a change to bevel horizontal siding, and becomes part of the house when connected with a breezeway. Or a traditional garage becomes a farm storage building with door and siding changes. The possibilities are literally endless.

If you don't see what you need or have questions about how a design can be adapted to your requirements, please give me a call, and I can probably help. Depending upon the requirements of your municipality, sometimes a quick phone conversation can solve the problem, other times a sketch is all that is needed. Custom designs or significant changes are available at a cost of \$1.50/sf of floor area.

**Customer Service: (609) 683 - 4388
9:00am - 2:00pm Eastern Time**

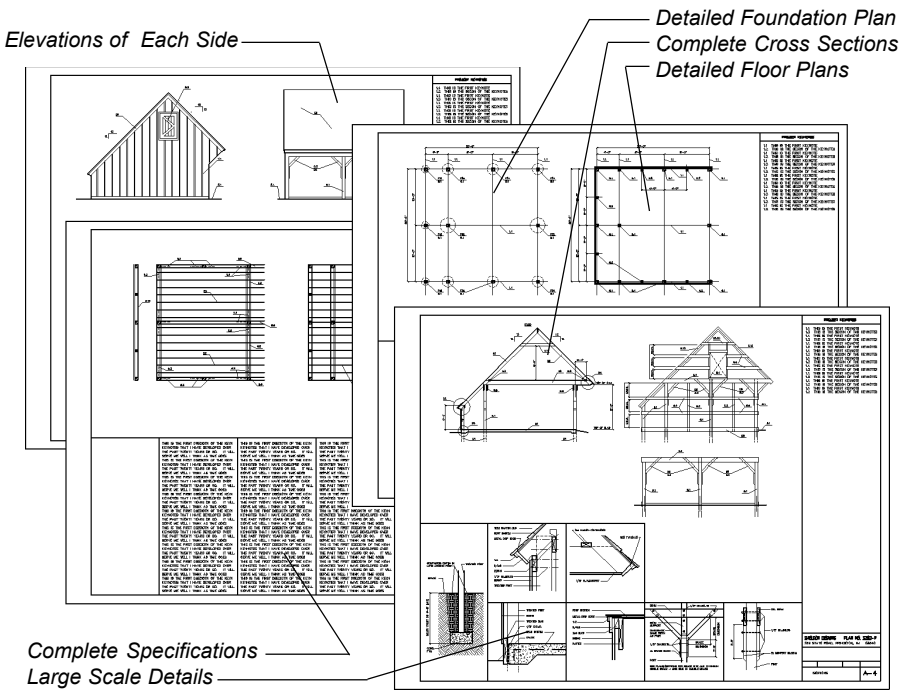

All designs and plans have been copyrighted.

What Your Blueprints Include

Your detailed blueprints include a foundation plan, floor plans, building sections, elevations of each side, and large scale details geared to make the building easy-to-build. You also get locations of electrical outlets, switches and lighting fixtures.

Local Codes and Restrictions

All the plans meet the CABO 1 and 2 Family Dwelling Code or the BOCA national code at the time the plans were made. Although designed under these nationally recognized codes, local variations, modifications, and interpretations make it impossible for us to guarantee compliance with every requirement of each locality.

Important Hints for Your Success

Because of varying conditions and local requirements, the heating and detailed plumbing design and engineering are not included and should be provided by local professionals familiar with your area. You should also make sure you have your local building professional review the plans to ensure compliance with all the local building and zoning codes, local ordinances, building and structural conventions, and any other local restrictions that might apply.

How to Order

After you have chosen the design(s) you want to order, fill in the order form as indicated then call, fax or mail your order to us.

Only if you are having the plans shipped to New Jersey, be sure to include the 6% sales tax.

How Many Sets Do You Need ?

One set is handy to study the design and construction details. If you plan to obtain cost estimates or build right away, you will need more sets. In addition to a set for yourself, you will typically need two for the building department, and two or more for the contractor.

Additional or Reverse Sets:

Additional sets or reverse prints of the same design are only \$15.00 if ordered within 30 days of your original order.

30-Day Money-Back Guarantee:

If you are not satisfied for any reason at all, simply return the order within 30 days for a full refund. If you prefer, you can exchange the plans for a different design and you will be credited the amount of the items returned.

Order Form

Important Hints for Your Success

Because of varying local conditions/requirements, you should make sure you have your local building professional review the plans to ensure compliance with all the local building/zoning codes and ordinances, building and structural conventions, and other local restrictions that might apply.

Ordering is Easy!

Qty	Plan Number and Description	Each	Total

Additional Sets \$15:	Subtotal	
Additional sets or reverse prints of the same design are only \$15 if ordered within 30 days of your original order.	NJ 6% Tax	
	Shipping	4.00
	Total Order	

30 Day Money-Back Guarantee

If you are not satisfied for any reason, simply return the order within 30 days for a full refund. If you prefer, you can exchange the plans for a different design and you will be credited the amount of the returned .

Order by Phone: 800-572-5934

By Fax: 609-683-5976

or send payment to:

Sheldon Designs

1330 Rt.204-#204 Skillman, NJ 08558

Order Data Check Money Order Credit Card

Name _____

Address _____

City _____ State _____ Zip _____

Credit Card Data M.C. Visa Amex Disc

Card Number _____ Expires _____

Signature _____ Telephone _____